

# Engine Identification

BMW engines are identified by a combined alpha-numeric code. Like the internal model designation it is a code used by the Engineering and Technical development teams during the design stages of the engine:

- M - for standard production engines
- S - for Motorsport engines (Motorsport is a separate division of BMW)
- N -for New Generation engines

After the letter there are two digits that identify the engine. The table below lists engines by number of cylinders. Please refer to the BMW Technical Information Card for individual model application.

<b>4 Cylinder</b>	M10: 1.8 & 2.0L 2 valve inline	M42: 1.8L 4 valve inline	M44: 1.9L 4 valve inline	S14: 2.3L 4 valve inline				
	M20: 2.5 & 2.7L 2 valve inline	M21: 2.4L 2 valve inline diesel turbo	M30: 2.8, 3.0, 3.2 3.4 & 3.5L 2 valve inline	M50: 2.5L 4 valve inline	M50TU: 2.5L 4 valve inline	M521: 2.5 & 2.8 L 4 valve inline	M52TU1: 2.5 & 2.8L 4 valve inline	M541: 2.5 & 3.0L 4 valve inline
<b>6 Cylinder</b>	M57D30T2 <sup>1</sup> : 3.0L 4 valve inline diesel bi-turbo	N52(K) <sup>1</sup> : 3.0L 4 valve inline	N54 <sup>1 3</sup> : 3.0L 4 valve inline bi-turbo	N55 <sup>1,2, 3</sup> : 3.0L 4 valve inline twin-scroll single turbo	S38: 3.5 & 3.6L 4 valve inline	S50: 3.0L 4 valve inline	S52 <sup>1</sup> : 3.2L 4 valve inline	S54: 3.2L 4 valve inline
	M60: 3.0 & 4.0L 4 valve V config.	M62: 4.4L 4 valve V config.	M62TU <sup>1</sup> : 4.4 & 4.6L 4 valve V config.	N62 <sup>1 2</sup> : 4.4L 4 valve V config.	N62 <sup>1 2</sup> : 4.8L 4 valve V config.	N62TU <sup>1 2</sup> : 4.8L 4 valve V config.	N63 <sup>1 3</sup> : 4.4L 4 valve V config. bi-turbo reverse flow	S62 <sup>1</sup> : 5.0L 4 valve V config.
<b>8 Cylinder</b>	S63 <sup>1 3</sup> : 4.4L 4 valve V config twin-scroll bi-turbo reverse flow	S65 <sup>1</sup> : 4.0L 4 valve V config.						
	S85 <sup>1</sup> : 5.0L 4 valve V config.		<b>12 Cylinder</b>	M70: 5.0L 2 valve V config.	M73: 5.4L 2 valve V config.	M73TU: 5.4L 2 valve V config.	N73 <sup>1 2 3</sup> : 6.0L 4 valve V config.	N74 <sup>1 3</sup> : 6.0L 4 valve V config. bi-turbo

**1** - VANOS: Variable Valve Timing. **2** - Valvetronic: Variable Valve Timing and Lift. **3** - Direct Injection

## Engine Numbering System

In order to organize and classify the engines developed by BMW, a numbering system has been developed.

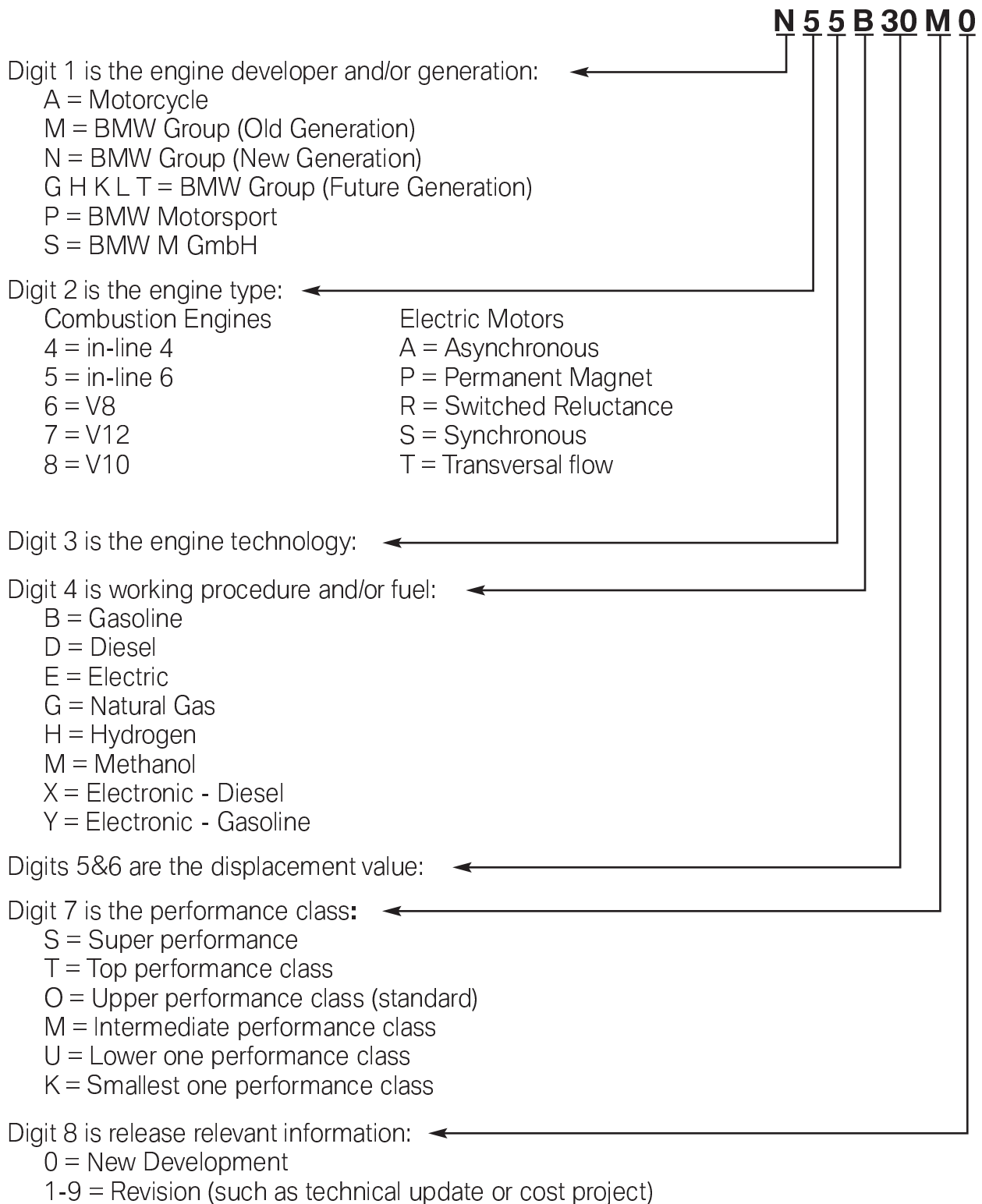

## Engine Displacement Identification

In technical literature usually only the group of 3 digits that follow the basic engine code is utilized for engine identification. These digits identify the required fuel type of the engine and its displacement.

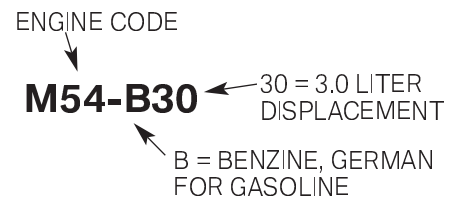

Engine displacement can always be determined by the engine specification plate. This plate is stamped onto the engines in various locations. There is a lot of information included in this identification plate. The breakdown of the information on this plate is as follows:

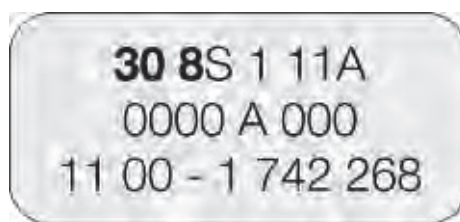

Powerplant Identification Code  
 Engine Number  
 Part Number

## Powerplant Identification Number

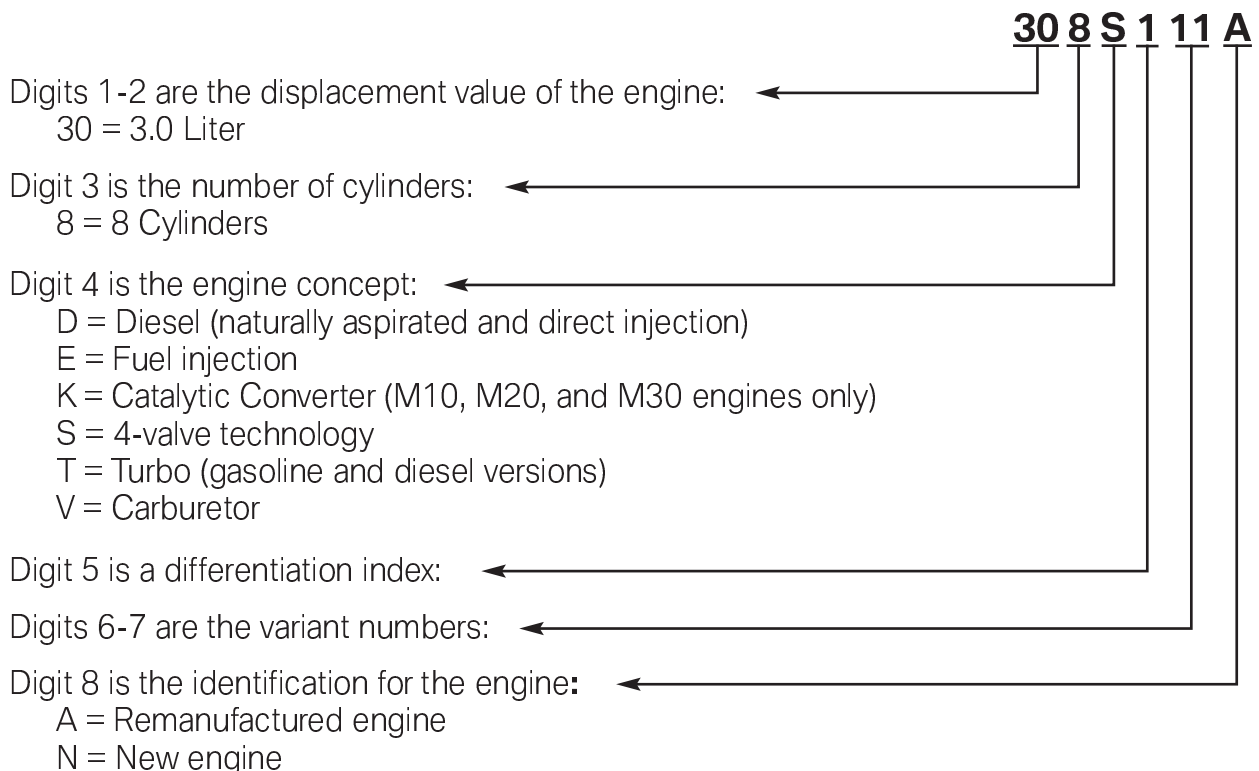

In recent time the Powerplant Identification Code changed from 8 digit to 7 digit. This mark is located on the crankcase to ensure unambiguous identification and classification. This engine identification is also necessary for approval by government authorities. Decisive here are the first seven positions. The first 6 positions are the same as the engine designation.

Item	Meaning	Index / explanation
1	Engine developer	M, N = BMW Group P = BMW Motorsport S = BMW M GmbH W = non-BMW engines
2	Engine type	5 = R6 (e.g. N55) 6 = V8 (e.g. N63) 7 = V12 (e.g. N73) 8 = V10 (e.g. S85)
3	Change to the basic engine concept	0 = basic engine 1 – 9 = changes, e.g. combustion process
4	Working method or fuel type and possibly installation position	B = petrol, longitudinal installation D = diesel, longitudinal installation H = hydrogen
5	Displacement in liters	1 = 1 liter (whole number of liters)
6	Displacement in 1/10 liter	8 = 0.8 liter (tenth of liter)
7	Type test concerns (changes that require a new type test)	A = Standard B – Z = Depending on requirement, e.g. RON 87

---

## Engine Specification Plate Locations

M20

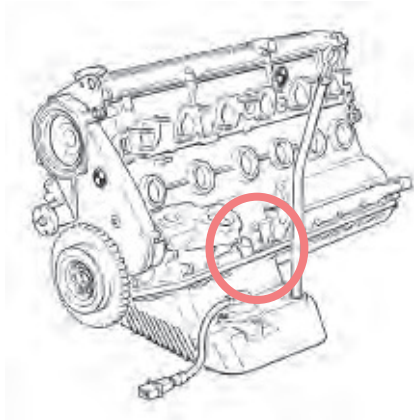

M30

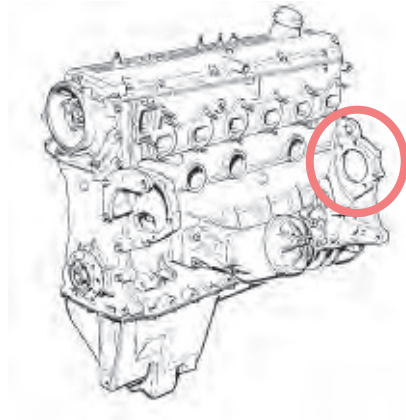

M42  
M44

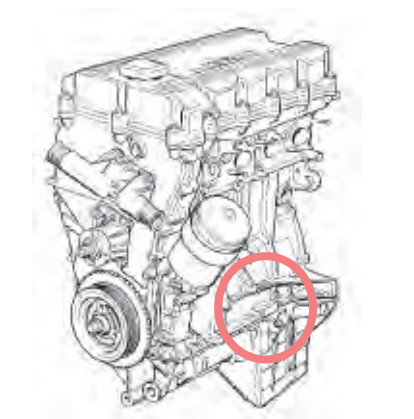

M50  
M52  
M54  
S50  
S52  
S54

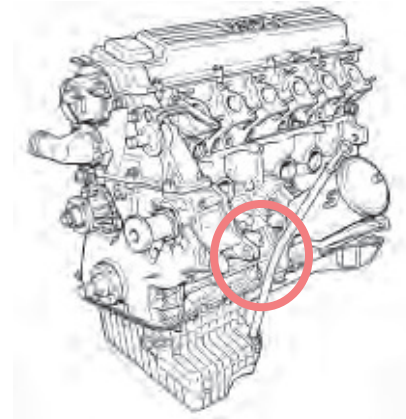

M60  
M62  
N62  
S62

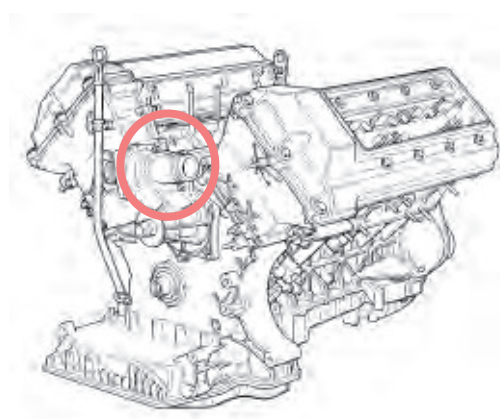

M70  
M73  
S70

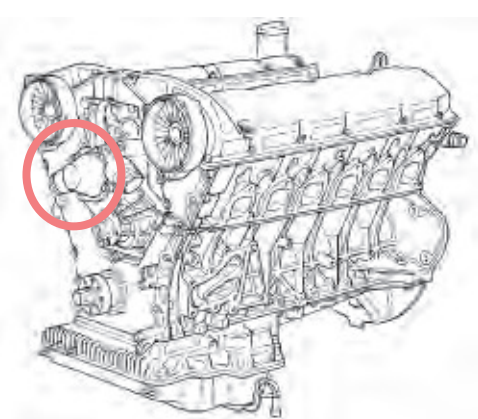

---

## Engine Specification Plate Locations (Cont.)

N52  
N54  
N55



N63  
S63

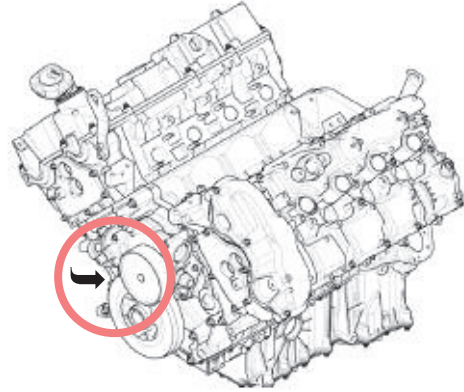

S65

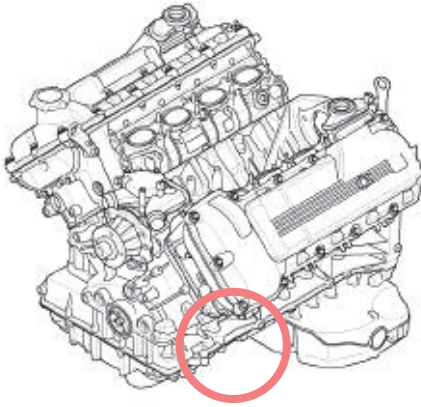

S85

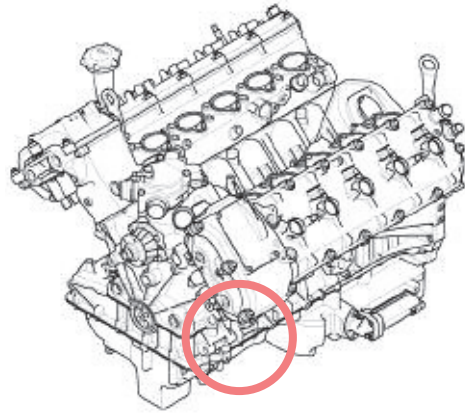

N74

